

RENEWABLE ENERGY TECHNOLOGIES FOR WATER AND WASTEWATER AND INDUSTRIAL APPLICATIONS

Water-Energy Nexus Operational Toolkit : Renewable Energy

11/07/2017

Economic and Social Commission for Western Asia

Prof. Hassan Arafat
ESCWA Consultant



UNITED NATIONS

الاسكوا

ESCWA

Outline

Introduction

RE sources

Water pumping and transport

Water heating

Oil & gas industry

Key messages



Introduction

W-E Nexus: Aspects and Opportunities

Renewable energy can boost water security by improving accessibility, affordability and safety;

Abstraction and conveyance, Treatment, Distribution, End-use, Wastewater collection and treatment, Constructing, operating and maintaining water-supply facilities



An energy system with substantial shares of renewable energy could be less water-intensive;

Extraction and mining, Fuel processing, Thermoelectric cooling, Transportation, Waste disposal and emission control, Constructing, operating and maintaining energy generation facilities

RE opportunities in the water-energy nexus:

- Reduce water-intensity of power sector
- Improve access to water
- Enhance reliability of water supply
- Bridge the water gap in arid regions
- Replace traditional water heating

RE across the water supply chain

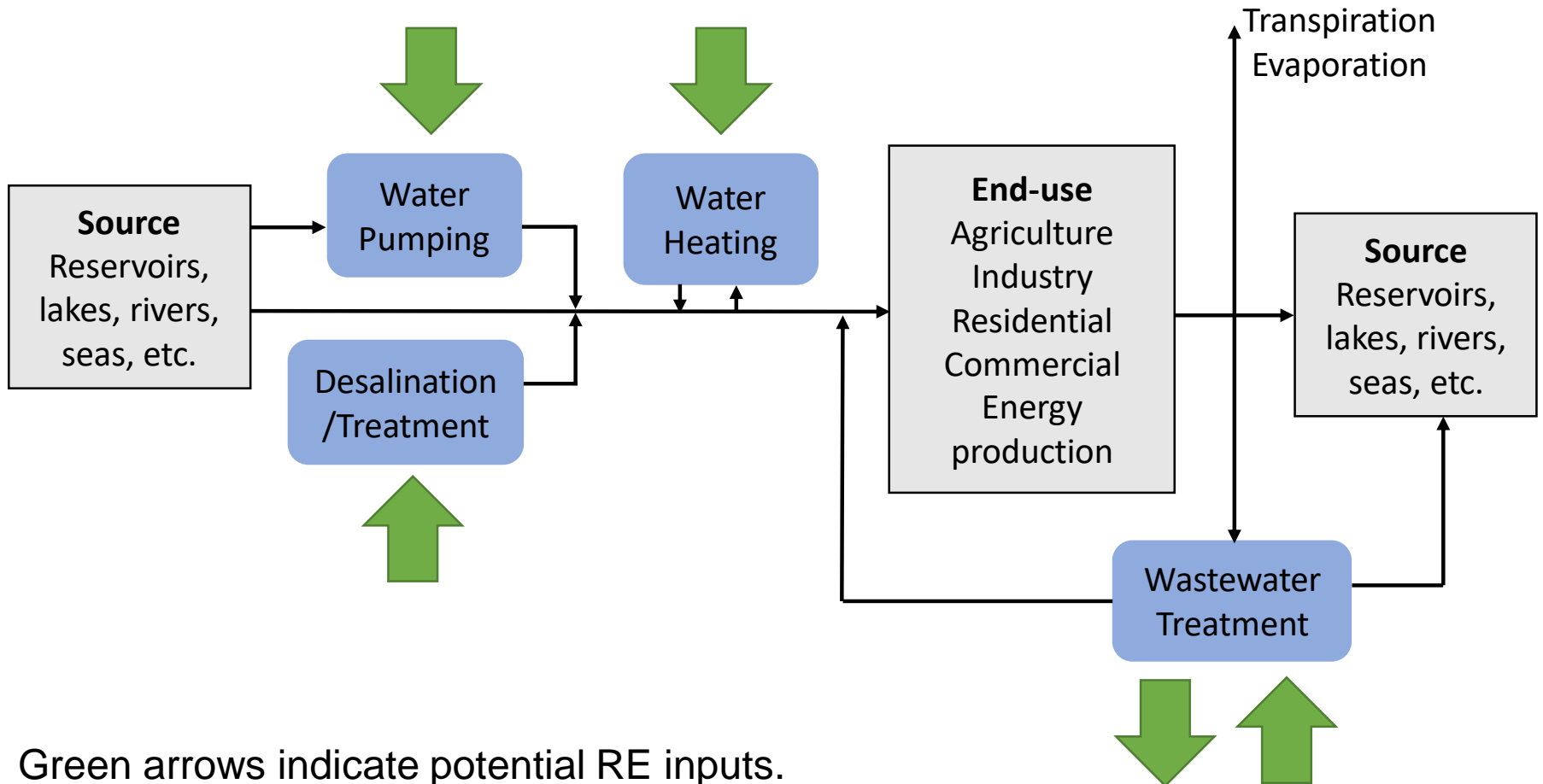

RE sources

RE sources

RE sources for wastewater treatment processes

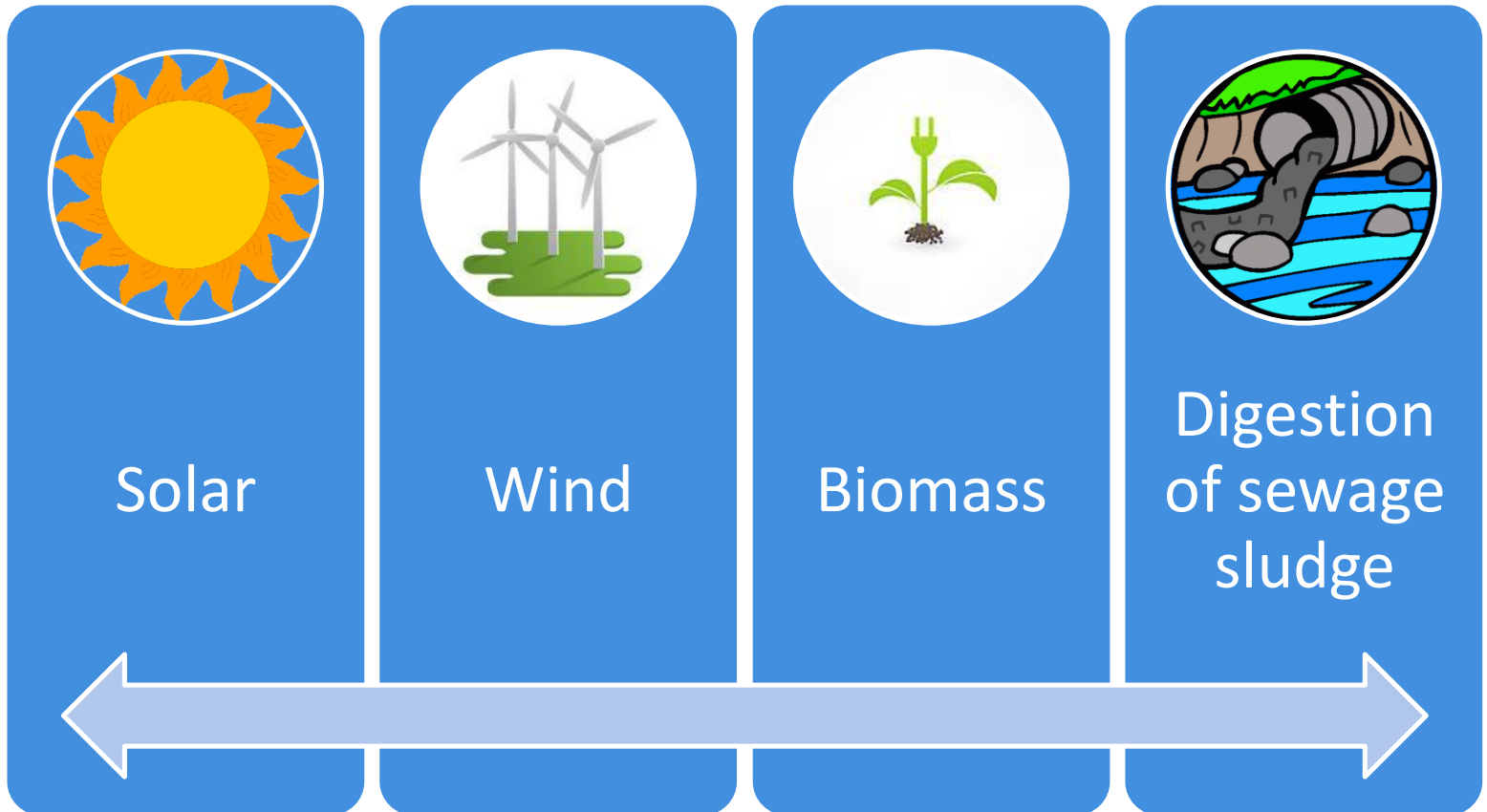

RE sources

Energy-producing WWTP

Process shown
is for Silicon
Valley.

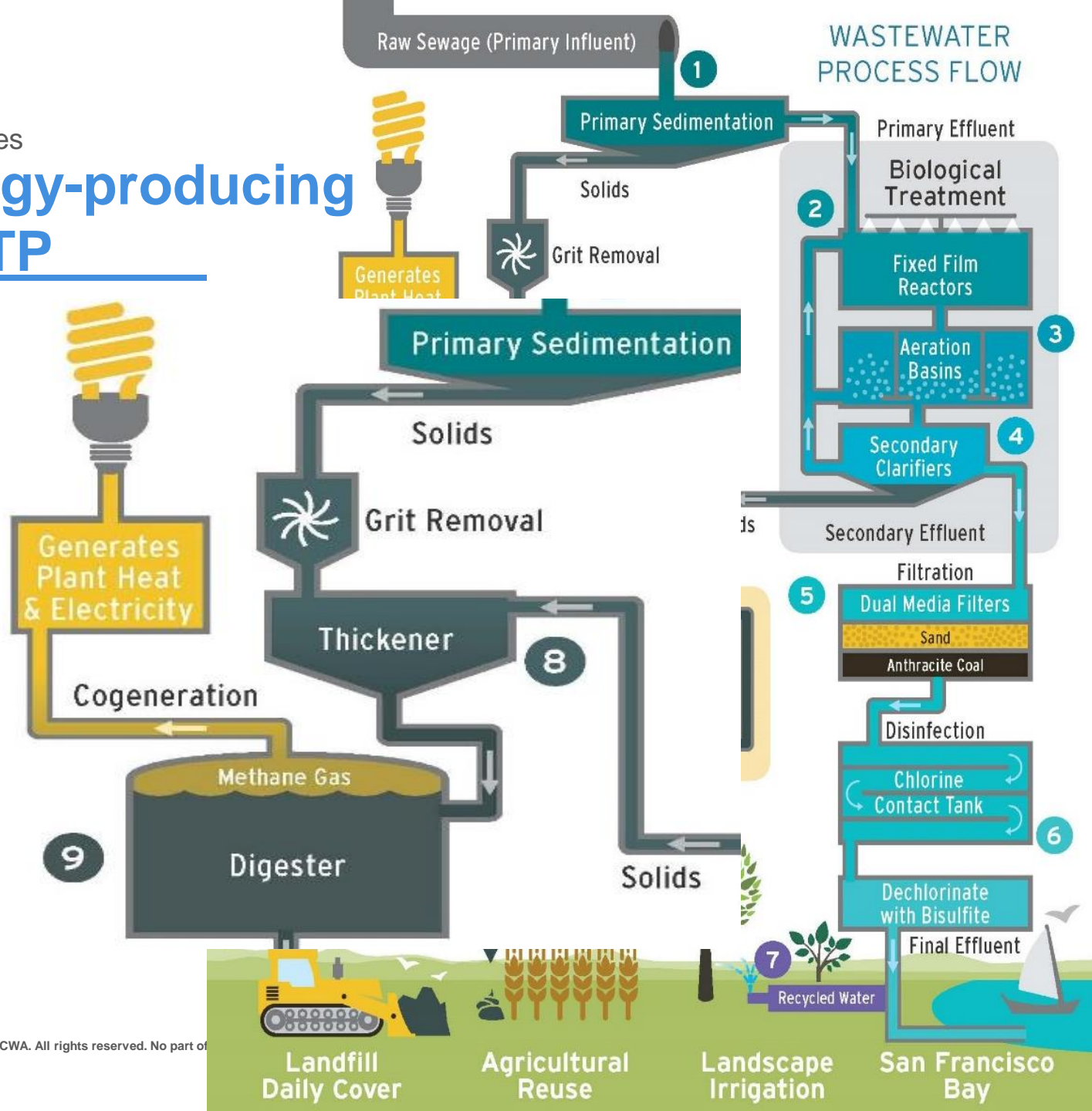

Source: Silicon Valley Clean Water (SVCW), 2012.

Combined Heat and Power (CHP)

Heat recovery integrated into the WWTP with AD to increase overall energy efficiency in a CHP system.

Thermal energy produced can be used to fulfill digester heat loads, etc.

CHP system provides more reliable and less costly electricity supply to the plant.

Conversion of biogas into electricity achieved using internal combustion engines (sizes vary from a few kWe to more than 4MWe), or micro-turbines (size variation: 30-250 kWe).

1 million gallons per day of wastewater can generate biogas which can produce 26 kilowatts (kW) of electricity and 2.4 million Btu per day of thermal energy through a CHP system.

RE sources

Typical values for operational parameters in biogas production in WWTPs

Operational Parameters	Typical Values
Hydraulic retention time (HRT)	16 – 25 days
Temperature	35 – 39 °C
Gross gas production and degradation of ODM	450 – 500 L/kg ODM or 18 – 26 L/PE/day
Degradation of ODM	45 – 55%
Methane content in biogas	63 – 67% CH ₄
Utilization of the biogas produced	95 – 99% (optimal range)
Electrical Efficiency of biogas conversion by CHP	100 kW: 25 – 35 % 100 – 500 kW: 5 – 40 % > 500 kW: 38 – 45 %
Electricity autonomy of the WWTP (in case of CHP use)	< 10,000 PE: 37% >100,000 PE: 68 – 100%
Heat autonomy of the WWTP (in case of CHP use)	90 – 100%
Electric energy generated	10 – 20 kWh /PE/year
Electric energy for AD	1 – 2.5 kWh/PE/year
Electric energy for sludge dewatering	0.5 – 3.5 kWh/PE/year
Thermal energy for sludge and reactor heating	8 – 16 kWh/PE/year

Water pumping and transport

Mechanical wind pumps (windmills)

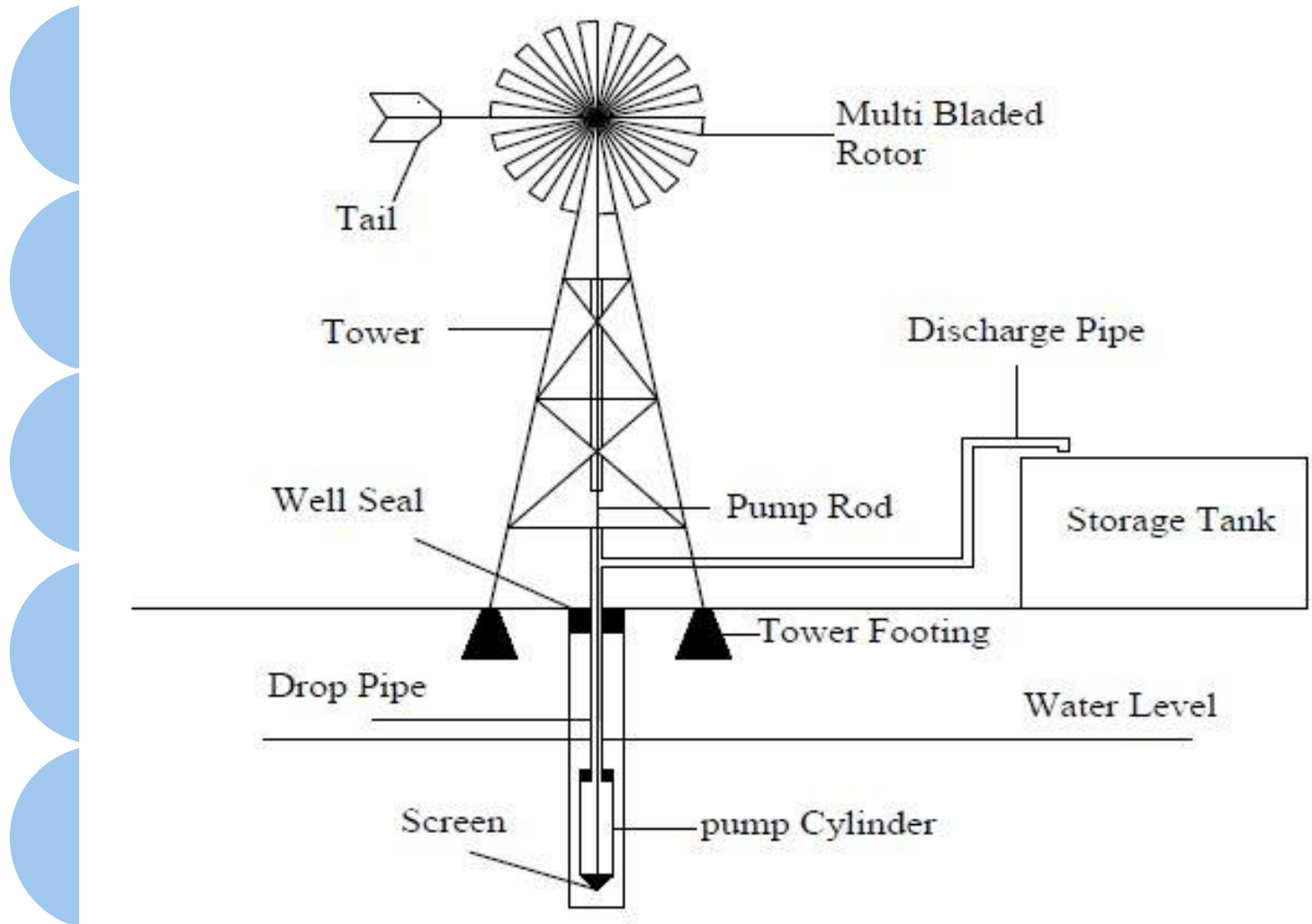

Water pumping and transport

Electrical wind turbines for powering water pumps

Electrical wind turbines can generate direct current (DC) or alternating current (AC) which power DC or AC motors respectively; Turbines most suitable for centrifugal pumps.

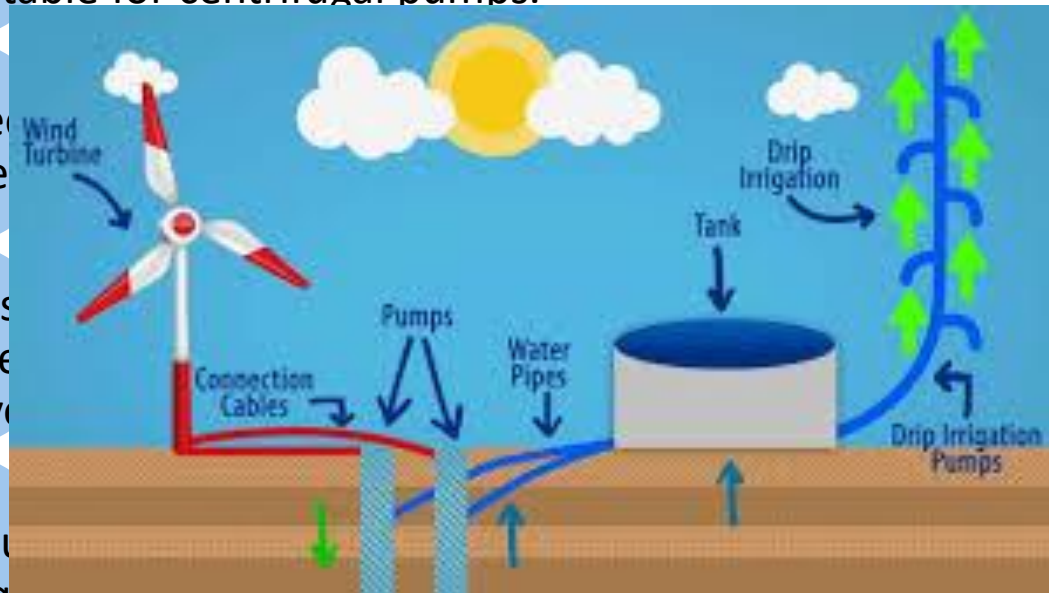

Electrical

Has effective investment

If turbines are required.

Electric wind turbines become competitive with windmills for water pumping applications when operated above an average wind speed of 5–6 m/s.

needs than

are, more cost-effective, more cost-effective, more cost-effective (about 40%).

converters are not

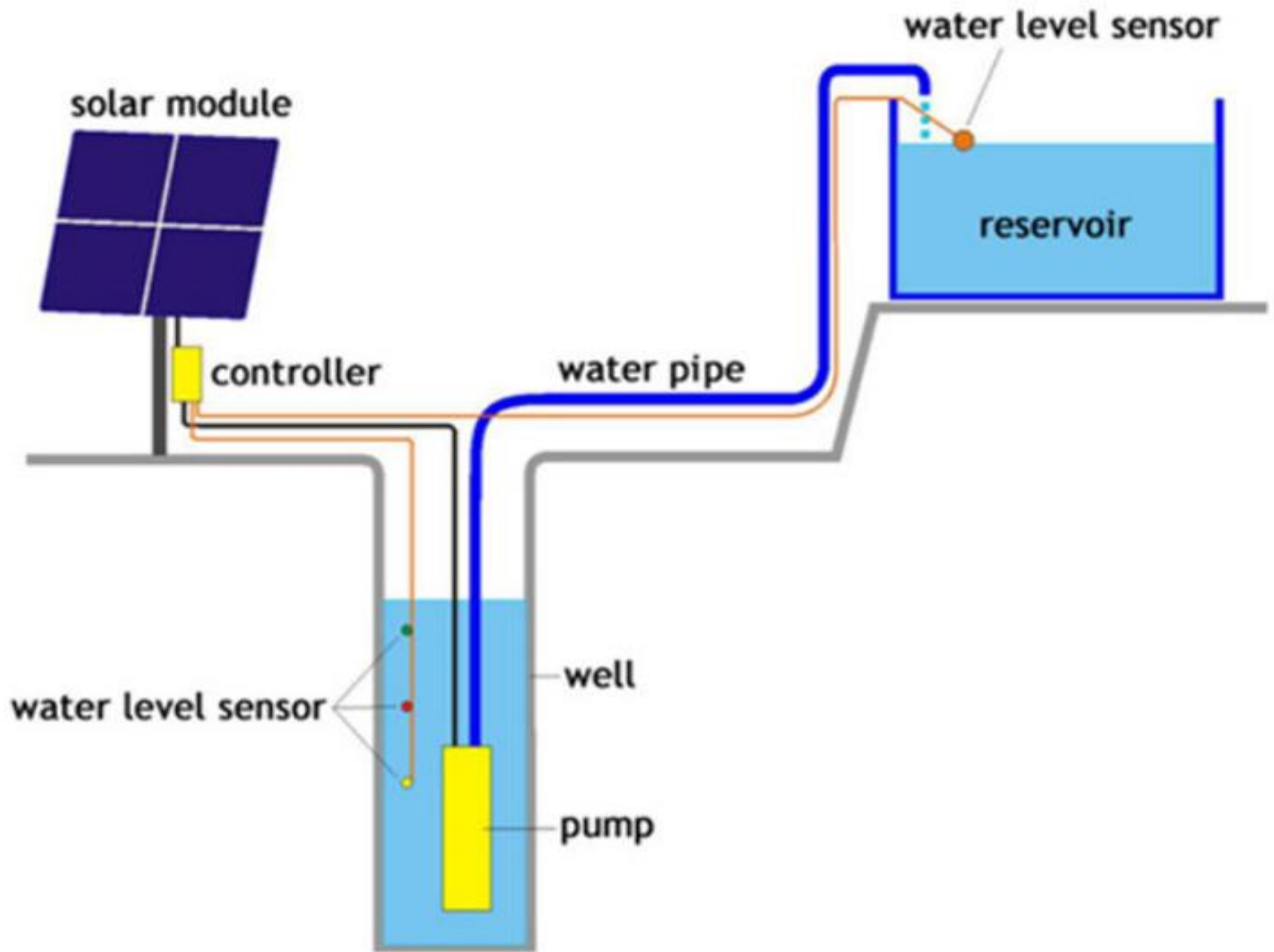

Biofuel pumps

Particularly useful for rural applications.

Feasible configuration tends to have dual fuel engine pumps (e.g. using both diesel and biofuel).

Higher O&M costs than other RE powered water pumping systems.

In water-scarce Arab countries valuable agricultural land ideally used to produce food and not fuel. Viable options only waste biomass or less water-intensive non-food crops.

Exception: Sudan. In 2016, 65 million tonnes of ethanol produced and in 2017 200 million tonnes to be produced. So it can be expected that biofuel will be used there to power water pumping and transport.

Water pumping and transport

Hybrid water pumping systems

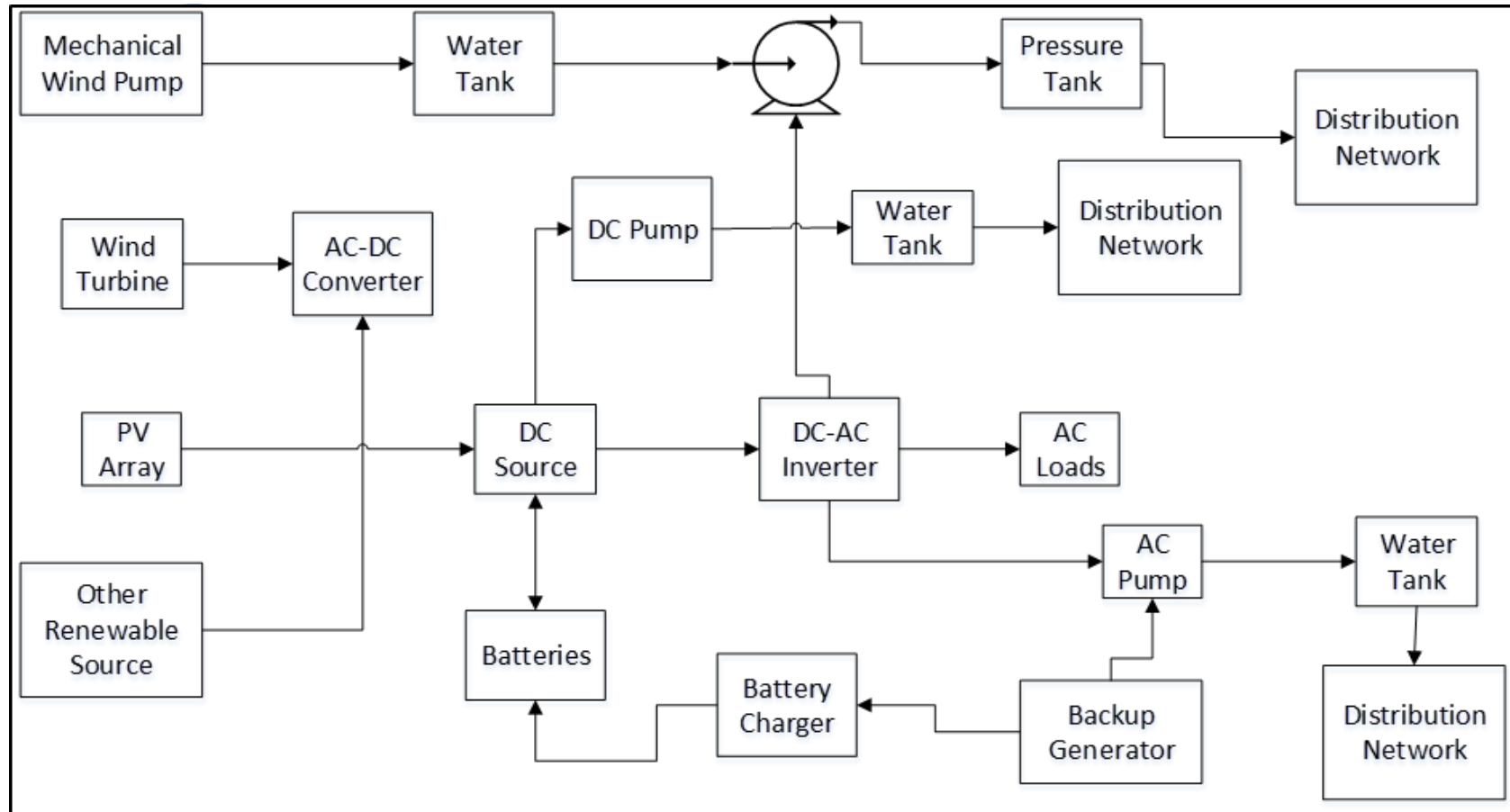

Capital costs can be quite high; Highly skilled individuals required for systems maintenance.

Water heating

Water heating

Solar water heating

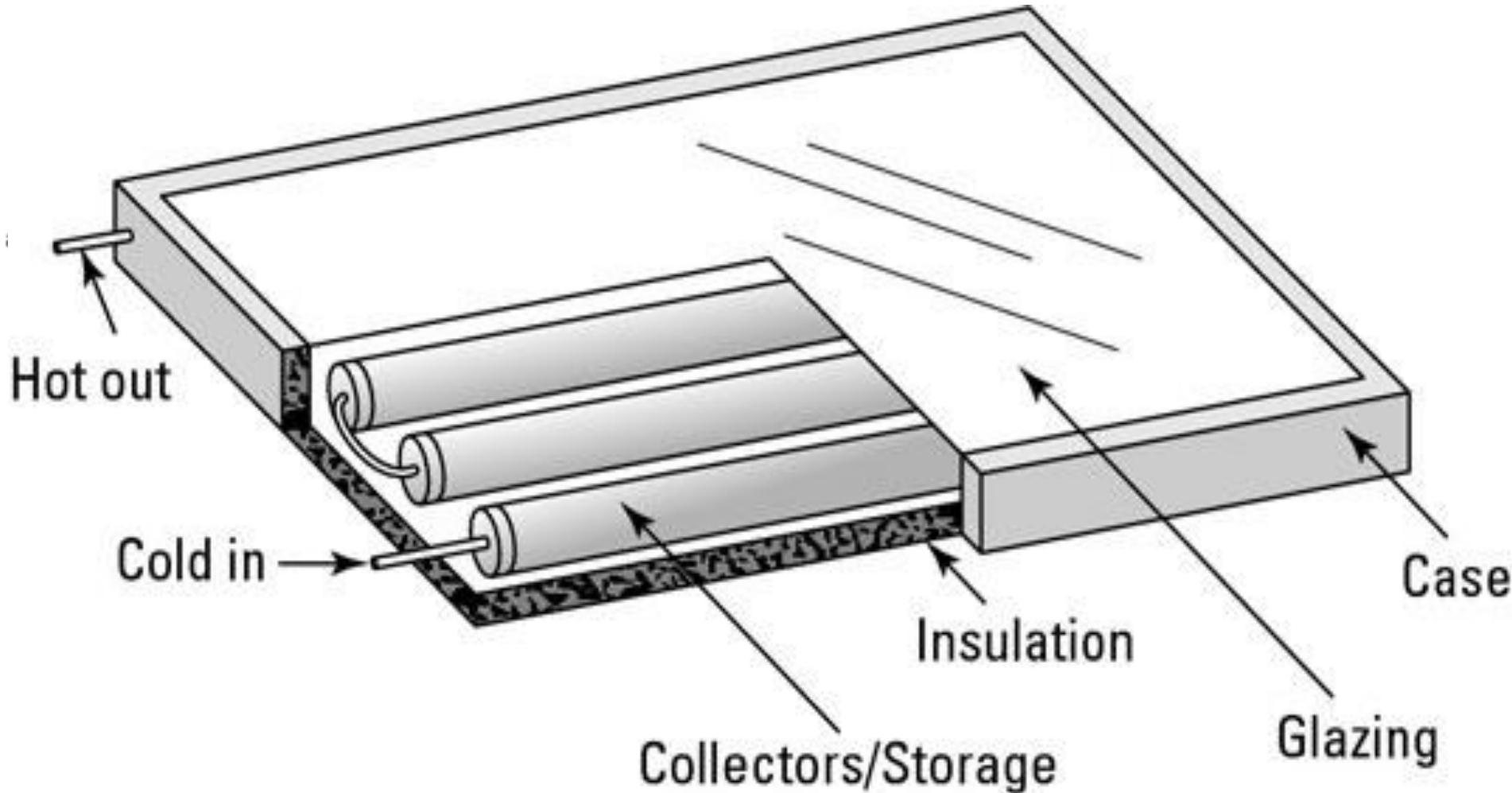

Pre-heating supply water of steam boilers

Helpful if high temperature feed water is required for industrial

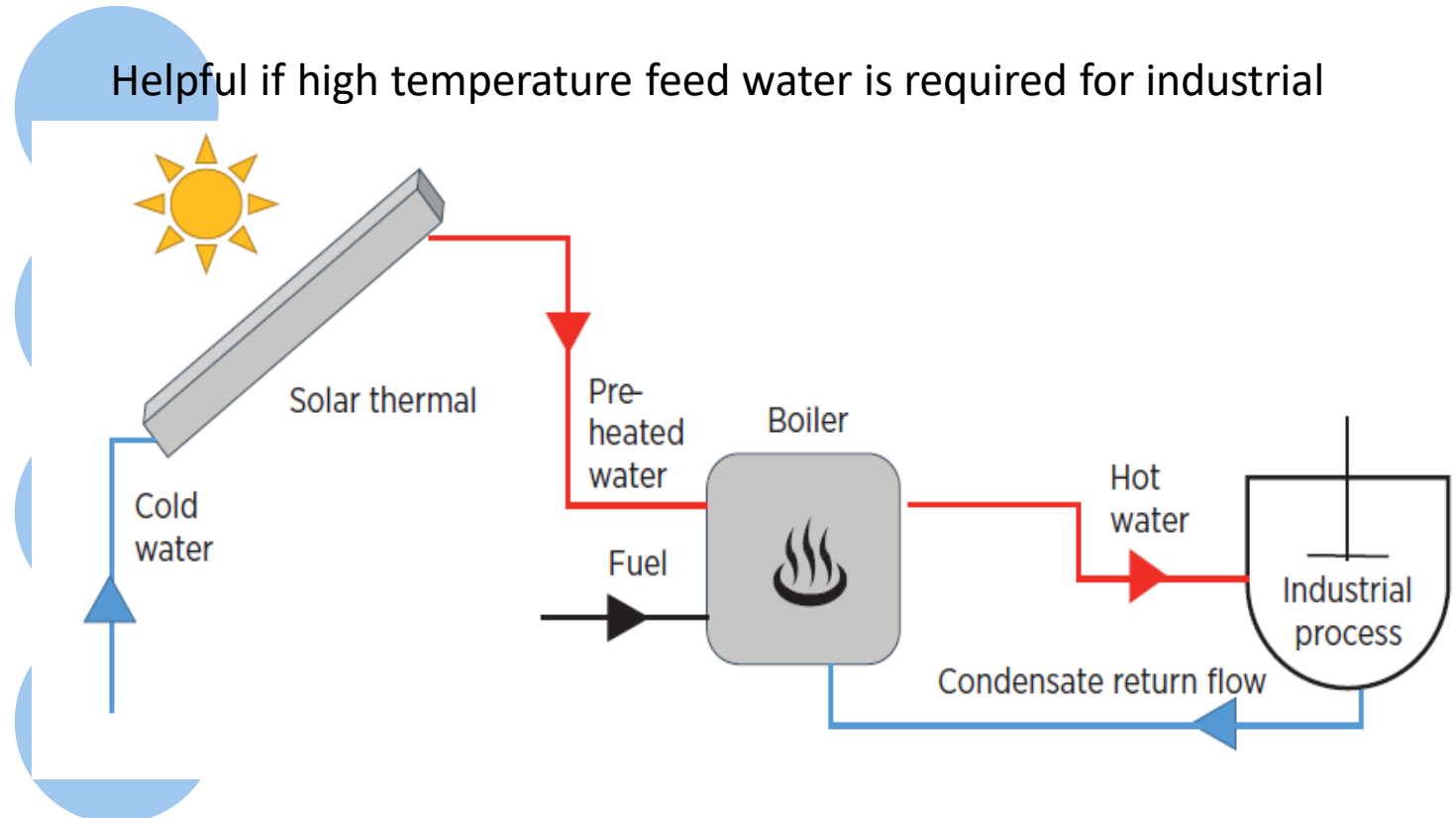

Solar fraction(Percentage of heating demand of a plant that can be met with solar process heating systems): can be $\approx 20\%$ and depends on amount of roof space which the plant has.

Prosol (Tunisian Solar Program)

- Provided solar water heater capital cost subsidies (20% subsidy) in the residential sector.
- Provided loans through commercial banks at a reduced interest rate to residential consumers.
 - Loans repaid through the state electricity utility via electricity bills.
 - State utility acted as debt collector, guarantor and enforcer.
- Achievements:
 - Has led to a ten-fold increase in solar water heating installations from 2004-2011.
 - Has led to a net gain in the public budget; savings are forecasted to reach US\$ 101 million over the lifespan of the solar water heaters (much greater than the government's initial investment of US\$ 21.8 million in the project).
 - Leading to a decrease in consumption of fossil fuels by 251 Ktoe over the lifespan of the solar water heaters.

Oil & gas industry

RE in the oil & gas sector

Worldwide, the most important heavy oil reserves are located in areas which receive high solar radiation.

Use of RE in upstream applications being achieved to a much greater extent than in downstream applications.

Most of the major oil companies power their special field applications using PV panels and Shell using combination of wind turbines and PV panels to help power some of its monotower platforms.

Solar EOR plant powered by CSP technology working successfully in Oman and being expanded. Currently helping reduce natural gas requirements by $\approx 49,500$ GJ annually.

By 2035, solar energy is forecasted to provide about 5% of the industry's energy needs (≈ 2 PJ of energy).

Solar EOR system for oil sands

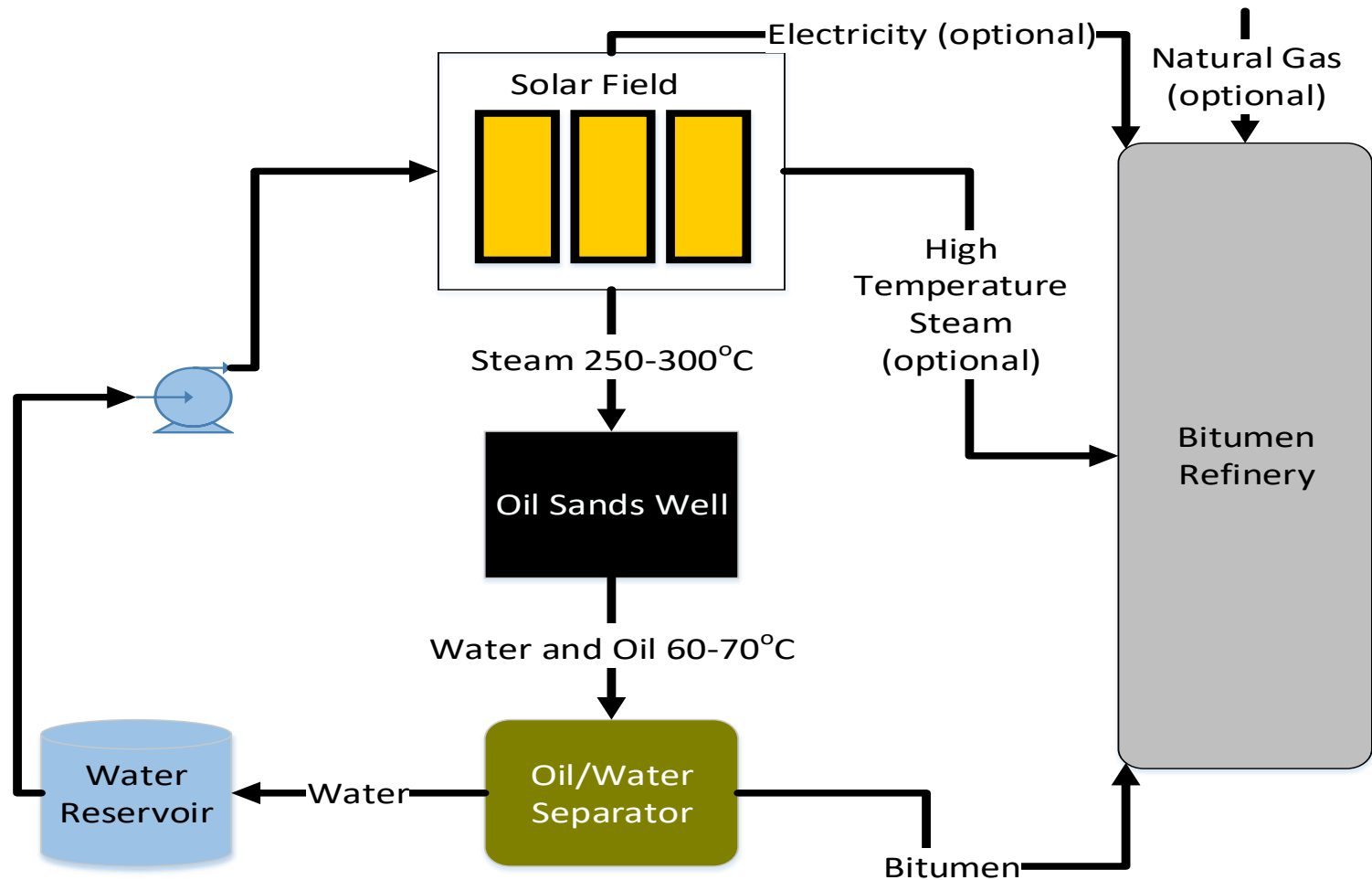

RE use in off-site petroleum reforming and cracking

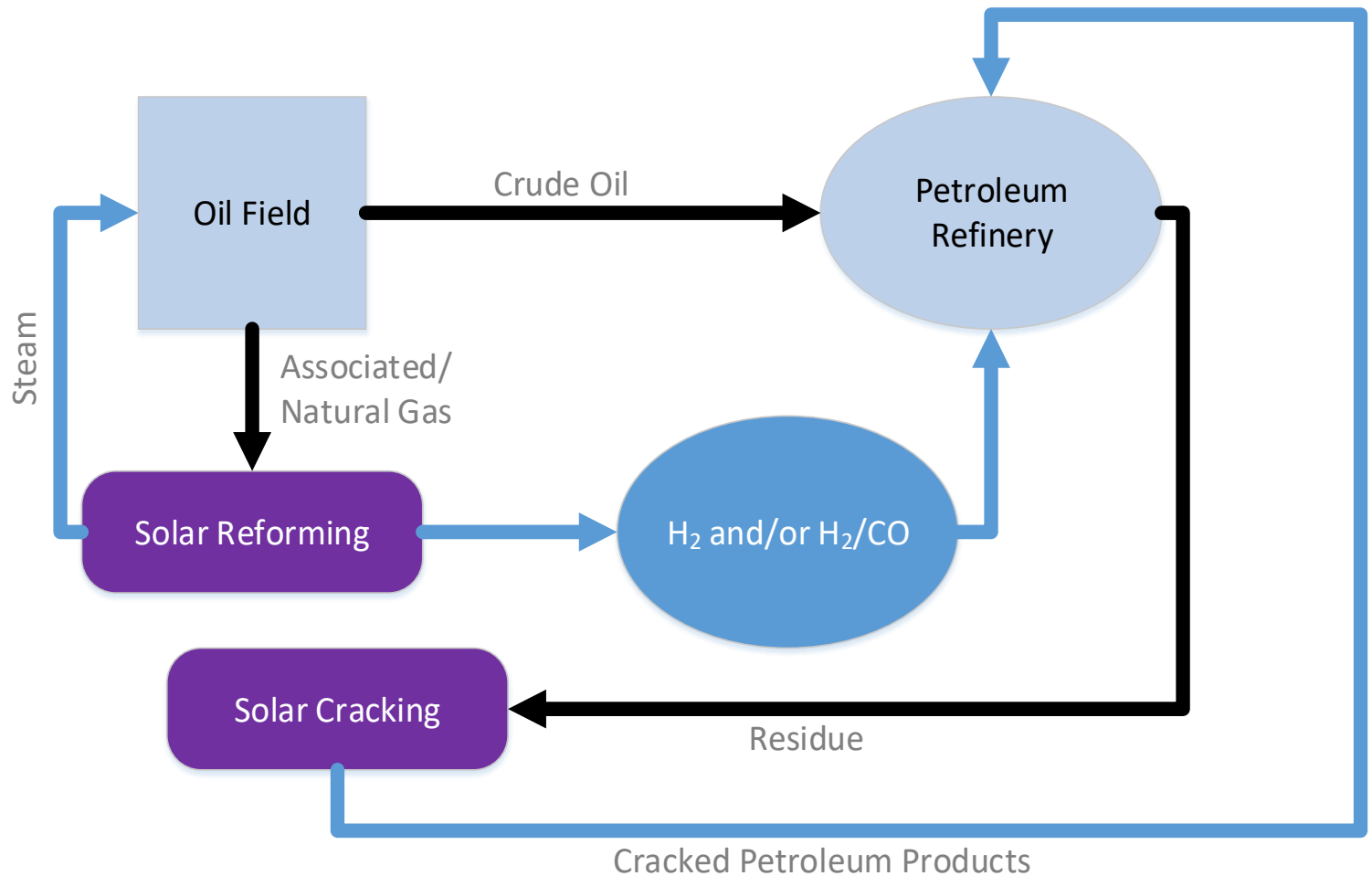

Key messages

- There are many opportunities for the use of RE technology to strengthen the security of the water-energy nexus.
- Anaerobic digestion of sewage sludge can be used to provide energy in WWTPs.
- Water pumps can be powered by solar, wind, or biofuel energy.
 - Hybrid pumps can be used which combine multiple RE sources or RE sources with conventional sources.
- Solar water heating has been implemented in the residential sector successfully in various Arab countries.
 - Solar collector options are flat-plate collectors (FPCs), evacuated tube collectors (ETCs), and the integral collector storage (ICS) system.
- The Oil & Gas sector is already using RE sources for certain operational activities.
 - Many more opportunities for the use of RE exist.
 - Solar energy will continue to grow in importance as an energy source for the Oil & Gas sector of the Arab countries.

THANK YOU

Economic and Social Commission for Western Asia



UNITED NATIONS

الاسكوا
ESCWA